

T0010506 THAI CHI WITH CHEST PRESS

T0010506 THAI CHI WITH CHEST PRESS

VISTA TRIDIMENSIONALE

THREE-DIMENSIONAL VIEW

SCHEDA TECNICA (TECHNICAL DATA SHEET)

ART. **T0010506**

21-05-2024

SCALA (SCALE)

LE MISURE SONO ESPRESSE IN MM. (MEASUREMENTS ARE EXPRESSED IN MM.)



TIEGI SRL
 VIA BENEDETTO CROCE 7,
 Z.I. "CONDOTTI BARDINI",
 31058 SUSEGANA (TV)
 0438-460519

FOGLIO 1 DI 5

PIANTA (PLAN)

4337

4654

1654

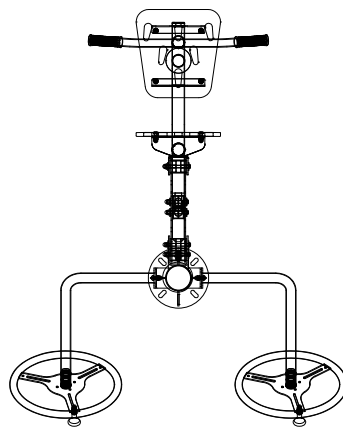

1337

AREA DI SICUREZZA (SECURITY AREA) 20 MQ

SCHEDA TECNICA (TECHNICAL DATA SHEET)

ART. T0010506

21-05-2024

SCALA (SCALE) 1:30

LE MISURE SONO ESPRESSE IN MM. (MEASUREMENTS ARE EXPRESSED IN MM.)



TIEGI SRL
VIA BENEDETTO CROCE 7,
Z.I. "CONDOTTI BARDINI",
31058 SUSEGANA (TV)
0438-460519

FOGLIO 2 DI 5



ALTEZZA DI CADUTA MAX.
(MAX. FALL HEIGHT): <100 cm



ALTEZZA D'USO (HEIGHT USE)
>140 cm



NUMERO UTILIZZATORI
(MAX N. OF SIMULTANEOUS USERS): 1



INGOMBRO (OVERALL DIMENSION)
165 cm X 134 cm X 200 cm H.



AREA DI SICUREZZA (SECURITY AREA)
465 cm X 434 cm



SUP. ANTITRAUMA CONSIGLIATA
(RECOMMENDED SAFETY SURFACING AREA)
20 MQ.

SCHEDA TECNICA (TECHNICAL DATA SHEET)

ART. T0010506

21-05-2024

SCALA (SCALE)

LE MISURE SONO ESPRESSE IN MM. (MEASUREMENTS ARE EXPRESSED IN MM.)



TIEGI SRL
VIA BENEDETTO CROCE 7,
Z.I. "CONDOTTI BARDINI",
31058 SUSEGANA (TV)
0438-460519

FOGLIO 3 DI 5

L'ATTREZZO È PROVVISORIO DI QR
CODE PER LA VISIONE DI VIDEO

ESPLICATIVO D'USO *(THE EQUIPMENT
IS PROVIDED WITH A QR CODE, DISPLAYING AN
EXPLANATORY VIDEO OF THE EXERCISE)*

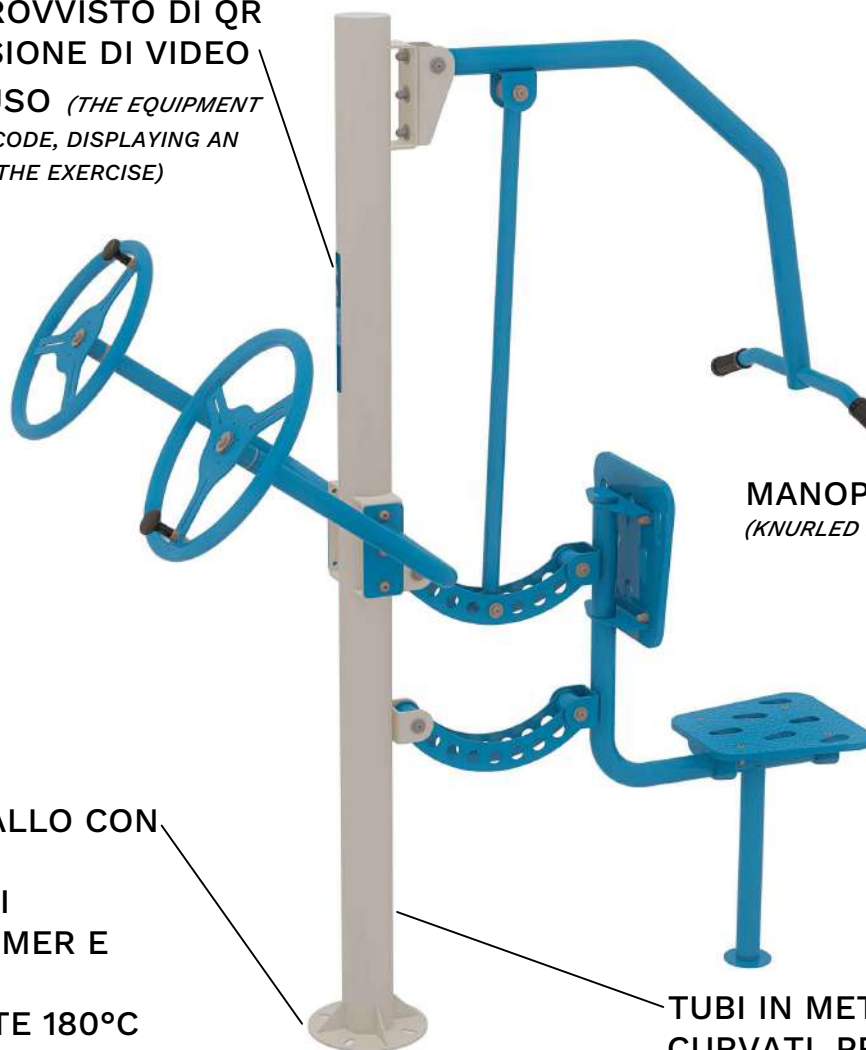

MANOPOLE ZIGRINATE
(KNURLED HANDLES)

PIASTRE IN METALLO CON
PROCESSO DI
VERNICIATURA DI
CATAFORESI, PRIMER E
VERNICIATURA
TERMOINDURENTE 180°C
*(METAL PLATES WITH CATAPHORESIS,
PRIMER AND 180°C THERMOSETTING
PAINTING PROCESS APPLIED)*

TUBI IN METALLO
CURVATI. PROCESSO DI
VERNICIATURA PER
CATAFORESI, PRIMER E
VERNICIATURA
TERMOINDURENTE
180°C
*(CURVED METAL TUBES.
CATAPHORESIS, PRIMER AND 180°C
THERMOSETTING PAINTING
PROCESS APPLIED)*

TUTTI GLI ELEMENTI DI FISSAGGIO,
VITI, DADI, RONDELLE ECC. SONO IN
ACCIAIO INOX

*(ALL FASTENERS, SCREWS, NUTS, WASHERS, ETC. ARE
MADE OF STAINLESS STEEL)*

SCHEMA TECNICA *(TECHNICAL DATA SHEET)*

ART. T0010506

21-05-2024

SCALA *(SCALE)*

LE MISURE SONO ESPRESSE IN MM. *(MEASUREMENTS ARE EXPRESSED IN MM.)*



TIEGI SRL
VIA BENEDETTO CROCE 7,
Z.I. "CONDOTTI BARDINI",
31058 SUSEGANA (TV)
0438-460519

FOGLIO 4 DI 5

VISTA FRONTALE
(FRONTAL VIEW)

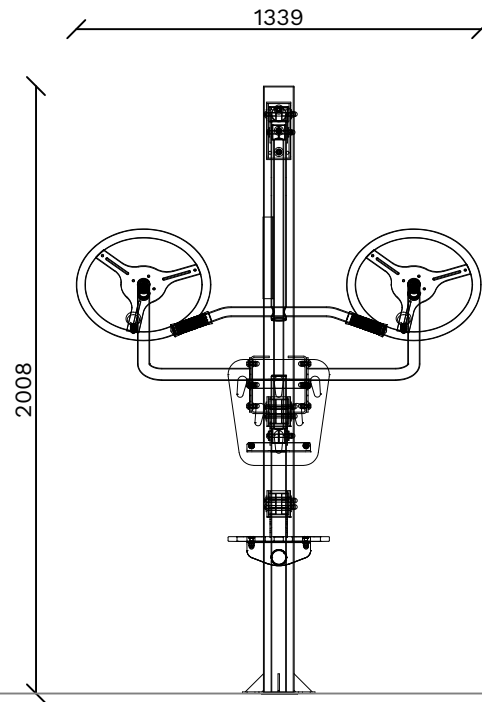

ALTEZZA MASSIMA
DI CADUTA LIBERA
(MAXIMUM HEIGHT OF THE
FREE FALL): < 100 cm

VISTA LATERALE
(LATERAL VIEW)

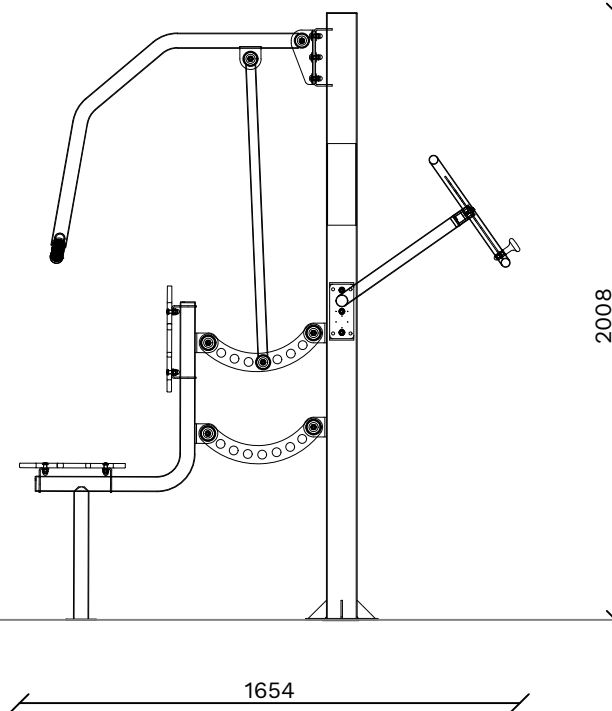

INGOMBRO MAX (OVERALL DIMENSIONS)

SCHEDA TECNICA (TECHNICAL DATA SHEET)

ART. T0010506

21-05-2024

SCALA (SCALE) 1:25

LE MISURE SONO ESPRESSE IN MM. (MEASUREMENTS ARE EXPRESSED IN MM.)



TIEGI SRL
VIA BENEDETTO CROCE 7,
Z.I. "CONDOTTI BARDINI",
31058 SUSEGANA (TV)
0438-460519

FOGLIO 5 DI 5